

Recycler guide, TOMRA R2-2

90431002



Original

Contents

About this guide.....	3
Disclaimer.....	4
Safety instructions.....	5
Disassembly instructions.....	7
Disassemble the TOMRA R2-2.....	7

About this guide

This product contains electrical and electronic components that should be recycled by a specialist electronics recycler. Disposal and recycling of products containing electrical and electronic components may be governed by national environmental legislation.

This guide provides information pertaining to the decommissioning and recycling of TOMRA reverse vending machines and backroom equipment pursuant to the European Community directive 2012/19/EU on waste electrical and electronic equipment (WEEE).

This information shall identify the different EEE components and materials, as well as the location of dangerous substances and mixtures in EEE so that they can be properly handled. If you have any questions or feedback regarding this guide, please contact us on www.tomra.com.

Disclaimer

This Recycler Guide is intended only for information purposes. It does not guarantee the composition of any product or that the product will retain a specific composition for a specific period.

The Recycler Guide provides information on the disassembly process of a product to assign the components to the correct recycling channels. The values given are only valid in this specified context and cannot be used to create the environmental compatibility assessment of a product.

Reuse of disassembled components is not permitted. TOMRA therefore assumes no liability for errors or consequences that may result from the use of this information for anything other than assigning the product components to the correct recycling channels.

Safety instructions

Introduction

TOMRA Systems ASA is not liable for any damage caused by incorrect actions taken during the disassembly of the product/system.

The recycler is responsible for ensuring the safety of its employees performing disassembly of TOMRA products.

Safety symbols

Safety symbols are used on the safety labels on TOMRA machines. The table below lists the commonly used symbols and explains what they mean. Not all warnings will be relevant for all products.



NOTE: These symbols are designed for machine use during operation. Not all warnings may be relevant for the purpose of recycling but may be useful to understand the components that are being disassembled.

Table 1: Mandatory actions







Symbol	Description
	Refer to the instructions.
	Use protective gloves.
	Use ear protection.
	Use eye protection.
	Switch off power before carrying out maintenance or repair.
	Disconnect the mains power cable before carrying out maintenance or repair.

Table 2: Prohibited actions









Symbol	Description
	Do not reach in.
	Do not clean with a hose or spray with water.
	Do not step on this surface.

Table 3: Warnings

Symbol	Description
	General warning sign. Indicates a warning, caution or presence of a hazard, specified by text or symbol.
	Electricity hazard: <ul style="list-style-type: none"> • Disconnect power before opening or handling • High voltage present • No serviceable parts inside
	The system can start without warning.
	Drawing in and crush hazard. Keep hands and clothes clear.
	Indicates an overhead obstacle.
	Tip-over hazard. The machine is top-heavy and may tip over when transported.

Disassembly instructions

Disassemble the TOMRA R2-2

Part ID

TOMRA R2-2 (90431002)

Recommended tools

- Socket wrenches 7, 8, 10, 13, 24 and 38 mm
- Torx screwdrivers T10, T20 and T30
- Allen keys 4 and 5 mm
- Crosshead screwdrivers PZ1, PZ2 and PZ3
- Flathead screwdriver, 4 mm
- Pick punch
- Hammer
- Pliers (universal, end-cutting and side-cutting)
- Stepladder
- Pallet truck



Disassemble all parts and sort the components per material types listed below. Do not mix material types.



NOTE: Circuit boards shall be destroyed/grinded.

Main parts



- 1. Front unit
- 2. Main unit

Material types



NOTE: There are variants of this machine, minor weight differences may occur.

Material	Weight (kg)
Steel	370.0
Aluminium	1.0
Other metal parts	1.0
Electrical, electronic and electromechanical (EEE) parts	22.5
Plastic	28.0
Rubber	1.0
Glass	6.5
Other parts	77.0
Total	507.0

Recommended disassembly procedure

Turn off power



WARNING: Before you start disassembling the machine, disconnect the main power source from all system modules.

If you cannot visually confirm the power is disconnected, you must use a multimeter and measure between the ground and all live wires to confirm there is no power in the component.

Make sure the main power source stays disconnected while you complete the disassembly.

Working on components connected to power can cause serious injury or death to personnel.

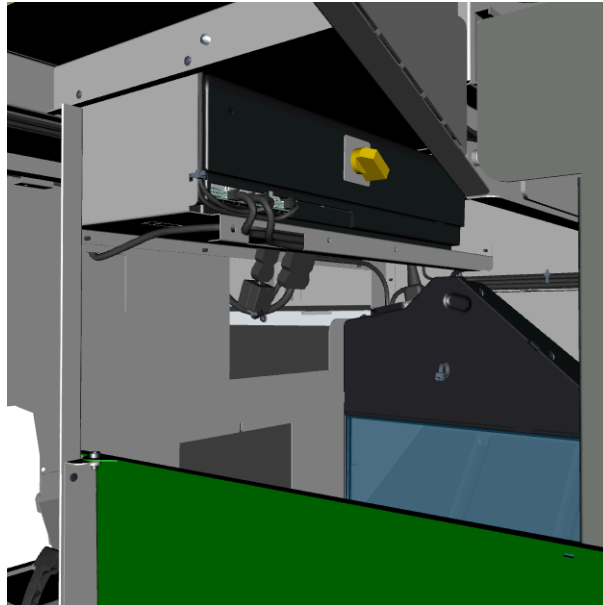

Step

- 1 Turn off power, then disconnect and remove the main power cable from the power source and from the machine.

Materials

EEE parts

Disassemble the front unit

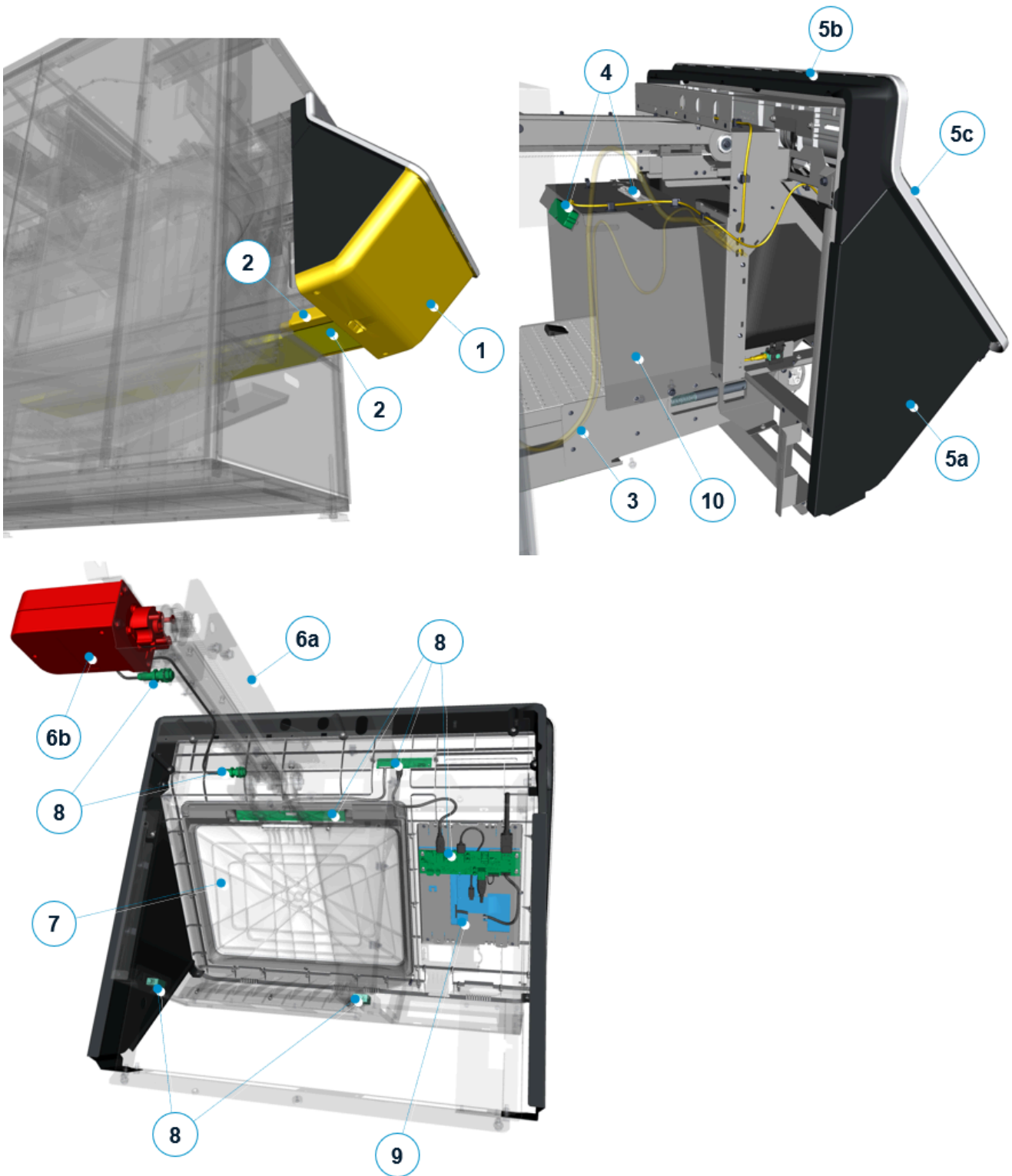

Step

- 1** Remove the bottom cover.
- 2** Remove the drip tray and the spill plate.
- 3** Detach the feeder conveyor and pull out the front unit on the feeder conveyor.
Disconnect and remove all the cables.

Materials

- Plastic, steel
- Steel
- EEE parts (cables)

Step	Materials
4 Remove the chute sensor and the hatch light.	Plastic, EEE parts (cables, circuit boards)
5 Remove the front unit from the feeder conveyor. Remove the side plates, the top cover and the dashboard.	Plastic
6 Remove the hatch motor unit, then remove the step motor	Steel, EEE parts (circuit boards, motor), plastic
7 Remove the hatch	Plastic
8 Remove the the sensors and the circuit boards.	EEE parts (circuit boards)
9 Remove the MMI unit with the display.	Steel., EEE parts (cables, circuit boards), plastic, glass, rubber
10 Remove the front-unit interface.	Steel, plastic
11 Discard the front unit frame.	Steel

Disassemble the main unit

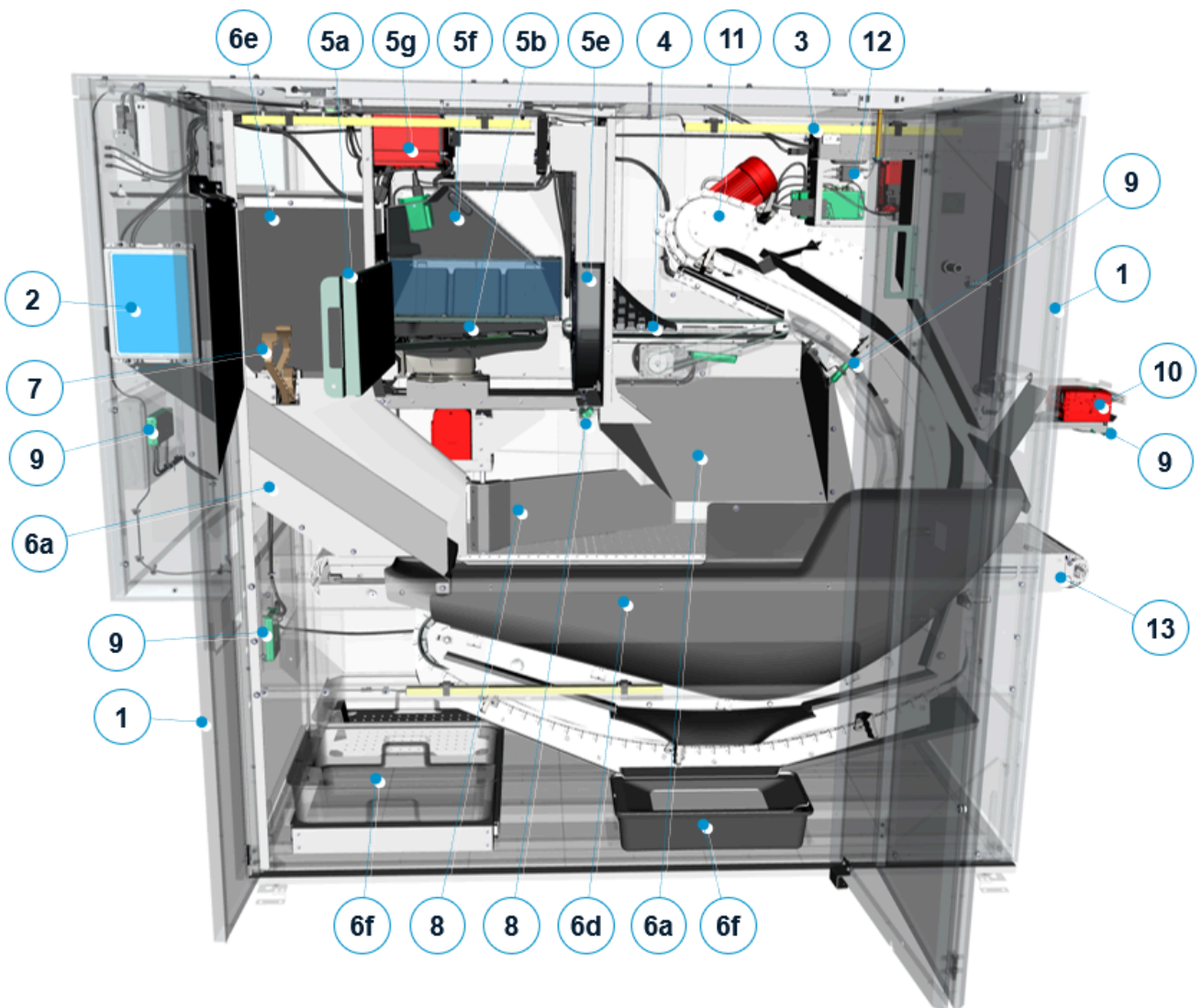

Step

- 1 Remove all covers and doors.
- 2 Remove the MMI unit at the rear.
- 3 Remove the 3 × cabinet light-bars.
- 4 Remove the main conveyor.



CAUTION: The transition guide has sharp edges. Wear cut-resistant protective gloves when handling the main conveyor.

- 5 Disassemble the recognition unit and remove the parts listed below:
 - a. Door with shape reflector
 - b. Infeed conveyor
 - c. Infeed docking-station
 - d. Arch reflector (if applicable)
 - e. OneRing reader, GSMU/DSMD (if applicable)
 - f. Shape-recognition unit
 - g. Power box



NOTE: The OneRing reader has a glass cover that shall be removed and recycled.

Materials

- Steel, plastic
- Steel, EEE parts (cables, circuit boards), plastic, glass, rubber
- EEE parts, plastic
- Steel, EEE parts (cables, circuit boards, motor), plastic

Steel, aluminium, EEE parts (cables, circuit boards, motor), plastic, glass, rubber

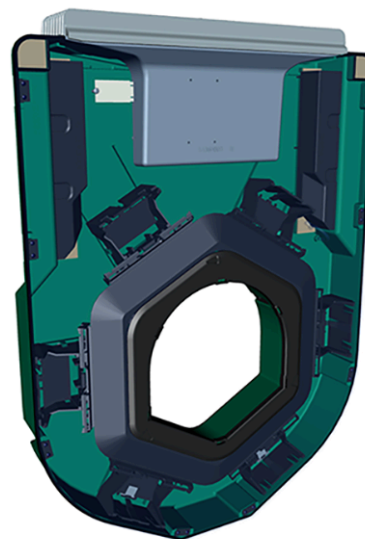

- 6 Remove the internal components listed below:
 - a. Chutes
 - b. Guides and guide plates
 - c. Horizontal support-plate
 - d. Reservoir parts
 - e. 3 × rubber curtains
 - f. Debris and drip trays

Steel, plastic

- 7 Remove the three-way sorter.
- 8 Remove the feeder gate with the step motor.
- 9 Remove all the remaining sensors and the driver boards.
- 10 Remove the printer unit with the printer.
- 11 Remove the singulation unit with the motor.
- 12 Remove the inverter unit.
- 13 Remove the feeder conveyor with the motor.
- 14 Remove the cables.
- 15 Disassemble the cabinet.

- Steel, EEE parts, plastic
- Steel, EEE parts (cables, circuit boards, motor), plastic
- Steel, EEE parts (cables, circuit boards), plastic
- Steel, EEE parts, plastic
- Steel, EEE parts (cables, circuit boards, motor), plastic
- Steel, EEE parts (cables, circuit boards), plastic
- Steel, aluminium, EEE parts (cables, circuit boards, motor), plastic
- EEE parts (cables)
- Steel

Step	Materials
16 Disassemble the assembled units.	Steel, aluminium, EEE parts (cables, circuit boards, motor), plastic, glass, rubber



TOMRA Systems ASA
Drengsrudhagen 2
NO-1385 Asker
NORWAY

www.tomra.com